

CD40106BM/CD40106BC Hex Schmitt Trigger

General Description

The CD40106B Hex Schmitt Trigger is a monolithic complementary MOS (CMOS) integrated circuit constructed with N and P-channel enhancement transistors. The positive and negative-going threshold voltages, V_{T+} and V_{T-} , show low variation with respect to temperature (typ 0.0005V/°C at $V_{DD} = 10V$), and hysteresis, $V_{T+} - V_{T-} \geq 0.2 V_{DD}$ is guaranteed.

All inputs are protected from damage due to static discharge by diode clamps to V_{DD} and V_{SS} .

Features

- Wide supply voltage range 3V to 15V
- High noise immunity 0.7 V_{DD} (typ.)
- Low power Fan out of 2 driving 74L
- TTL compatibility or 1 driving 74LS
- Hysteresis 0.4 V_{DD} (typ.)
- Equivalent to MM54C14/MM74C14 0.2 V_{DD} guaranteed
- Equivalent to MC14584B

Connection Diagram

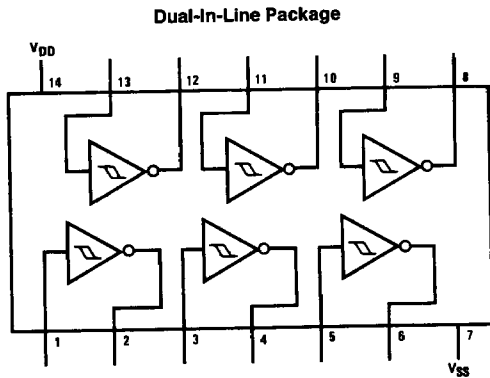

Switching Time Waveforms

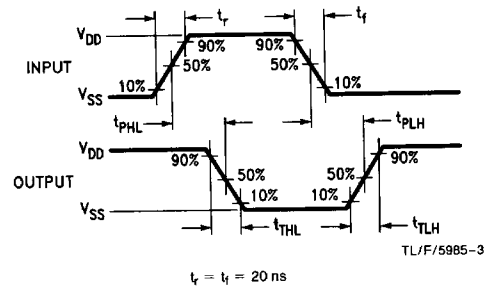

Order Number CD40106B*

*Please look into Section 8, Appendix D for availability of various package types.

Schematic Diagram

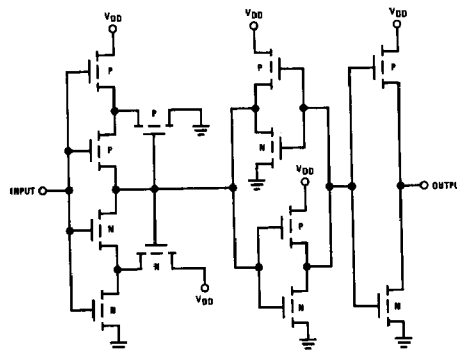

Absolute Maximum Ratings (Notes 1 & 2)

If Military/Aerospace specified devices are required, contact the National Semiconductor Sales Office/Distributors for availability and specifications.

DC Supply Voltage (V_{DD})	-0.5 to +18 V_{DC}
Input Voltage (V_{IN})	-0.5 to V_{DD} + 0.5 V_{DC}
Storage Temperature Range (T_S)	-65°C to +150°C
Power Dissipation (P_D)	
Dual-In-Line	700 mW
Small Outline	500 mW
Lead Temperature (T_L)	
(Soldering, 10 seconds)	260°C

Recommended Operating Conditions (Note 2)

DC Supply Voltage (V_{DD})	3 to 15 V_{DC}
Input Voltage (V_{IN})	0 to V_{DD} V_{DC}
Operating Temperature Range (T_A)	
CD40106BM	-55°C to +125°C
CD40106BC	-40°C to +85°C

DC Electrical Characteristics CD40106BM (Note 2)

Symbol	Parameter	Conditions	-55°C		+25°C			+125°C		Units
			Min	Max	Min	Typ	Max	Min	Max	
I_{DD}	Quiescent Device Current	$V_{DD} = 5V, V_{IN} = V_{DD}$ or V_{SS}		1.0			1.0		30	μA
		$V_{DD} = 10V, V_{IN} = V_{DD}$ or V_{SS}		2.0		2.0		60	μA	
		$V_{DD} = 15V, V_{IN} = V_{DD}$ or V_{SS}		4.0		4.0		120	μA	
V_{OL}	Low Level Output Voltage	$ I_O < 1 \mu A$								
		$V_{DD} = 5V$		0.05			0.05		0.05	V
		$V_{DD} = 10V$		0.05			0.05		0.05	V
		$V_{DD} = 15V$		0.05			0.05		0.05	V
V_{OH}	High Level Output Voltage	$ I_O < 1 \mu A$								
		$V_{DD} = 5V$	4.95		4.95	5		4.95		V
		$V_{DD} = 10V$	9.95		9.95	10		9.95		V
		$V_{DD} = 15V$	14.95		14.95	15		14.95		V
V_{T-}	Negative-Going Threshold Voltage	$V_{DD} = 5V, V_O = 4.5V$	0.7	2.0	0.7	1.4	2.0	0.7	2.0	V
		$V_{DD} = 10V, V_O = 9V$	1.4	4.0	1.4	3.2	4.0	1.4	4.0	V
		$V_{DD} = 15V, V_O = 13.5V$	2.1	6.0	2.1	5.0	6.0	2.1	6.0	V
V_{T+}	Positive-Going Threshold Voltage	$V_{DD} = 5V, V_O = 0.5V$	3.0	4.3	3.0	3.6	4.3	3.0	4.3	V
		$V_{DD} = 10V, V_O = 1V$	6.0	8.6	6.0	6.8	8.6	6.0	8.6	V
		$V_{DD} = 15V, V_O = 1.5V$	9.0	12.9	9.0	10.0	12.9	9.0	12.9	V
V_H	Hysteresis ($V_{T+} - V_{T-}$)	$V_{DD} = 5V$	1.0	3.6	1.0	2.2	3.6	1.0	3.6	V
		$V_{DD} = 10V$	2.0	7.2	2.0	3.6	7.2	2.0	7.2	V
		$V_{DD} = 15V$	3.0	10.8	3.0	5.0	10.8	3.0	10.8	V
I_{OL}	Low Level Output Current (Note 3)	$V_{DD} = 5V, V_O = 0.4V$	0.64		0.51	0.88		0.36		mA
		$V_{DD} = 10V, V_O = 0.5V$	1.6		1.3	2.25		0.9		mA
		$V_{DD} = 15V, V_O = 1.5V$	4.2		3.4	8.8		2.4		mA
I_{OH}	High Level Output Current (Note 3)	$V_{DD} = 5V, V_O = 4.6V$	-0.64		-0.51	-0.88		-0.36		mA
		$V_{DD} = 10V, V_O = 9.5V$	-1.6		-1.3	-2.25		-0.9		mA
		$V_{DD} = 15V, V_O = 13.5V$	-4.2		-3.4	-8.8		-2.4		mA
I_{IN}	Input Current	$V_{DD} = 15V, V_{IN} = 0V$		-0.10		-10 ⁻⁵	-0.10		-1.0	μA
		$V_{DD} = 15V, V_{IN} = 15V$		0.10		10 ⁻⁵	0.10		1.0	μA

Note 1: "Absolute Maximum Ratings" are those values beyond which the safety of the device cannot be guaranteed. They are not meant to imply that the devices should be operated at these limits. The table of "Recommended Operating Conditions" and "Electrical Characteristics" provides conditions for actual device operation.

Note 2: $V_{SS} = 0V$ unless otherwise specified.

Note 3: I_{OH} and I_{OL} are tested one output at a time.

DC Electrical Characteristics CD40106BC (Note 2)

Symbol	Parameter	Conditions	-40°C		+25°C			+85°C		Units
			Min	Max	Min	Typ	Max	Min	Max	
I _{DD}	Quiescent Device Current	V _{DD} = 5V V _{DD} = 10V V _{DD} = 15V		4.0 8.0 16.0			4.0 8.0 16.0		30 60 120	μA μA μA
V _{OL}	Low Level Output Voltage	I _O < 1 μA V _{DD} = 5V V _{DD} = 10V V _{DD} = 15V		0.05 0.05 0.05			0.05 0.05 0.05		0.05 0.05 0.05	V V V
V _{OH}	High Level Output Voltage	I _O < 1 μA V _{DD} = 5V V _{DD} = 10V V _{DD} = 15V	4.95 9.95 14.95		4.95 9.95 14.95	5 10 15		4.95 0.95 14.95		V V V
V _{T-}	Negative-Going Threshold Voltage	V _{DD} = 5V, V _O = 4.5V V _{DD} = 10V, V _O = 9V V _{DD} = 15V, V _O = 13.5V	0.7 1.4 2.1	2.0 4.0 6.0	0.7 1.4 2.1	1.4 3.2 5.0	2.0 4.0 6.0	0.7 1.4 2.1	2.0 4.0 6.0	V V V
V _{T+}	Positive-Going Threshold Voltage	V _{DD} = 5V, V _O = 0.5V V _{DD} = 10V, V _O = 1V V _{DD} = 15V, V _O = 1.5V	3.0 6.0 9.0	4.3 8.6 12.9	3.0 6.0 9.0	3.6 6.8 10.0	4.3 8.6 12.9	3.0 6.0 9.0	4.3 8.6 12.9	V V V
V _H	Hysteresis (V _{T+} - V _{T-}) Voltage	V _{DD} = 5V V _{DD} = 10V V _{DD} = 15V	1.0 2.0 3.0	3.6 7.2 10.8	1.0 2.0 3.0	2.2 3.6 5.0	3.6 7.2 10.8	1.0 2.0 3.0	3.6 7.2 10.8	V V V
I _{OL}	Low Level Output Current (Note 3)	V _{DD} = 5V, V _O = 0.4V V _{DD} = 10V, V _O = 0.5V V _{DD} = 15V, V _O = 1.5V	0.52 1.3 3.6		0.44 1.1 3.0	0.88 2.25 8.8		0.36 0.9 2.4		mA mA mA
I _{OH}	High Level Output Current (Note 3)	V _{DD} = 5V, V _O = 4.6V V _{DD} = 10V, V _O = 9.5V V _{DD} = 15V, V _O = 13.5V	-0.52 -1.3 -3.6		-0.44 -1.1 -3.0	-0.88 -2.25 -8.8		-0.36 -0.9 -2.4		mA mA mA
I _{IN}	Input Current	V _{DD} = 15V, V _{IN} = 0V V _{DD} = 15V, V _{IN} = 15V		-0.30 0.30		-10 ⁻⁵ 10 ⁻⁵	-0.30 0.30		-1.0 1.0	μA μA

AC Electrical Characteristics*

T_A = 25°C, C_L = 50 pF, R_L = 200k, t_r and t_f = 20 ns, unless otherwise specified

Symbol	Parameter	Conditions	Min	Typ	Max	Units
t _{PHL} or t _{PLH}	Propagation Delay Time from Input to Output	V _{DD} = 5V V _{DD} = 10V V _{DD} = 15V		220 80 70	400 200 160	ns ns ns
t _{rHL} or t _{rLH}	Transition Time	V _{DD} = 5V V _{DD} = 10V V _{DD} = 15V		100 50 40	200 100 80	ns ns ns
C _{IN}	Average Input Capacitance	Any Input		5	7.5	pF
C _{PD}	Power Dissipation Capacity	Any Gate (Note 4)		14		pF

*AC Parameters are guaranteed by DC correlated testing.

Note 1: "Absolute Maximum Ratings" are those values beyond which the safety of the device cannot be guaranteed, they are not meant to imply that the devices should be operated at these limits. The table of "Recommended Operating Conditions" and "Electrical Characteristics" provides conditions for actual device operation.

Note 2: V_{SS} = 0V unless otherwise specified.

Note 3: I_{OH} and I_{OL} are tested one output at a time.

Note 4: C_{PD} determines the no load ac power consumption of any CMOS device. For complete explanation see 54C/74C Family Characteristics Application Note, AN-90.

5

Typical Applications

Low Power Oscillator

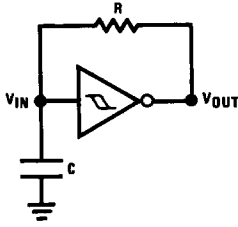

$$t_1 \approx RC \ln \frac{V_{T+}}{V_{T-}}$$

$$t_2 \approx RC \ln \frac{V_{DD} - V_{T-}}{V_{DD} - V_{T+}}$$

$$f \approx \frac{1}{RC \ln \frac{V_{T+} (V_{DD} - V_{T-})}{V_{T-} (V_{DD} - V_{T+})}}$$

Note: The equations assume $t_1 + t_2 \gg t_{PHL} + t_{PLH}$

TL/F/5985-4

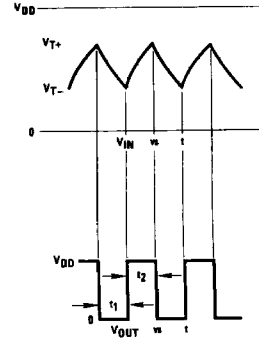

TL/F/5985-5

Typical Performance Characteristics

Typical Transfer Characteristics

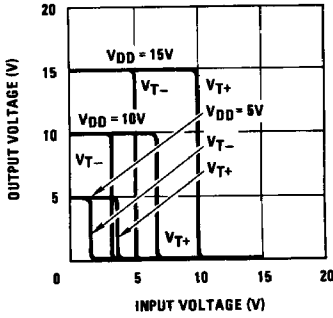

TL/F/5985-6

Guaranteed Trip Point Range

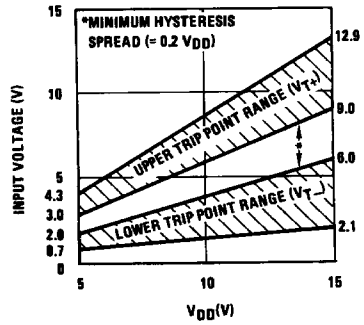

TL/F/5985-7

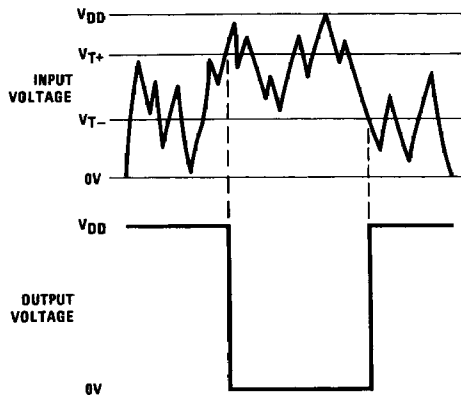

TL/F/5985-8