

FEATURING

- **Operable as a Digital or an Analogue Amplifier**
- **Output Power** Specified as a digital amplifier for corrected average powers up to 30 kW. Rated as a common amplifier from 44 kW peak sync. vision plus 4.4 kW single carrier aural to 55 kW peak sync. vision plus 7.7 kW single carrier aural. Rated as a vision amplifier from 55 to 77 kW.
- **Common Amplifier Mode** A Figure of Merit of 100% can be achieved.
- **Frequency Range** 470 to 810 MHz (Bands IV and V) in a single tube and circuit.
- **Simple Tube Exchange** Continuously tunable external cavities, with digital frequency indicators. This means that a replacement tube will be coarse tuned on installation, needing only trimming adjustments.
- **Simple, Efficient Cooling** Air-cooled cavities and gun. Liquid cooled body and collector.
- **Easy to Tune Input Cavity** Input cavity has a single tuning control.
- **Long Life** High reliability electron gun with barium aluminate cathode and pyrolytic graphite grid.
- **All Ceramics Aluminium Oxide** No beryllium oxide hazard.

DESCRIPTION

IOTD2100 is a high efficiency Inductive Output Tube amplifier for use in the output stage of transmitters in UHF television service.

The IOT has an electromagnetically focused electron beam which is density bunched using a rugged grid driven by an RF input cavity. The IOT beam power varies with the instantaneous output power.

The circuit assembly is designed so that the cavities can be detached from the vacuum tube and refitted on a replacement without disturbing the tuning. Therefore the replacement IOT is coarse tuned at switch-on and requires only trimming adjustments. A feature of the cavity design is that tuning of each cavity including the input cavity, is by means of a single control. A numerical indication of the cavity frequency is provided.

The electron gun and cavities require forced-air cooling; the circuit assembly incorporates a distribution manifold for which the cooling air must be adequately filtered to avoid electrostatic precipitation of dust on insulators.

The IOT body and collector are liquid cooled and the exit coolant must be led to a separate heat exchanger (not supplied).



Access to the high voltage electron gun connections of the IOT is via a removable lid on the top of the input cavity. The lid carries a high voltage warning label and the appropriate international symbol. The input cavity is fitted with a microswitch to enable the transmitter circuits to show that the lid is in place and secure. The transmitter can thus be fitted with an executive function to disconnect the high voltage power supply if the input cavity lid is not in place or properly secured.

ABRIDGED DATA

| | | |
|-----------------------------------|------------|-----|
| Frequency range | 470 to 810 | MHz |
| Power gain (see note 1) | 20.5 to 23 | dB |
| Beam voltage | 32 to 36 | kV |

Digital

| | | |
|--|-----------|----|
| Peak output power at IOT flange | up to 110 | kW |
| Average output power (corrected) | up to 30 | kW |

Analogue

| | | |
|---|-----------------------------------|----|
| Output power (common amplification) (see note 2) | up to 55 kW vision + 5.5 kW aural | |
| Output power (vision only) | up to 77 | kW |

GENERAL

Electrical

| | |
|---|-------------------|
| Cathode | indirectly heated |
| Heater voltage (see note 3) | 6.25 to 7.5 V dc |
| Heater current range | 20 to 30 A |
| Cathode pre-heating time | 10 minutes |
| Ion pump to cathode voltage | +3.0 to 4.0 kV |
| Internal impedance of ion pump supply | 500 kΩ approx |

Mechanical

| | |
|---|------------------------------|
| Overall length | 80.5 cm (31.69 inches) nom |
| Overall diameter (excluding anode water pipes) | 23.4 cm (9.21 inches) nom |
| Mounting position | vertical, collector end down |
| Net weight of IOT | 29 kg (64 pounds) approx |
| Net weight of circuit assembly | 113 kg (250 pounds) approx |
| Net weight of tuning cavities | 40 kg (88 pounds) approx |

Circuit Assembly IMD2000 Series

The choice of circuit assembly for the IOTD2100 depends on the operating channel. Broadcasters wishing to operate the IOT at frequencies between 614 and 632 MHz should use circuit assembly type IMD2001.

| | | |
|---------------------------------|--|---|
| Electromagnet voltage | 5.0 to 7.0 | V |
| Electromagnet current | 22 to 26 | A |
| RF input connector | type N coaxial (male) | |
| RF output | 3 ¹ / ₈ inch 50 Ω coaxial line | |

Cooling

| | |
|--|---|
| Air flow to cavities and cathode terminal (see note 4) | 2.0 m ³ /min 70.6 cfm |
| Static pressure head (see note 5) | 1.27 kPa 5.0 inches w.g. |
| Inlet air temperature | 60 °C max |
| Minimum water flow required for collector at maximum output power | 45 l/min 11.9 US gal/min |
| Collector pressure drop at 45 l/min | 165 kPa 23.9 psi |
| Minimum body cooling required | 5 l/min at 304 kPa 1.32 US gal/min at 44 psi |
| Inlet pressure | 410 kPa max 60 psi max |
| Water outlet temperature | 70 °C max |
| Water inlet temperature | 50 °C max |

Tube Protection

Arc detector type MA257E is fitted to each of the primary and secondary output cavities. The beam voltage and drive power must be removed within 100 ms of an arc being established.

| | |
|-----------------------------------|----------------|
| Photo-resistor type | VT43N2 |
| Minimum dark resistance | 300 kΩ |
| Resistance at 10 lux | 8 to 24 kΩ |
| Maximum voltage (peak) | 250 V |
| Maximum temperature | 75 °C |
| Test lamp | 24 V 0.04 A |
| Connections | see page 9 |

MAXIMUM RATINGS

The transmitter must be provided with a fast disconnect circuit which operates in the event of an internal arc (see note 6). If the maximum rating for any of the parameters listed below is exceeded, the beam voltage must be removed within 100 ms from the instant at which the rating is exceeded. In either case, the beam voltage must not be re-applied within 5 seconds.

| | | |
|---|-------|------|
| Heater starting current (peak) | 60 | A |
| Beam voltage (see note 7) | 38 | kV |
| Quiescent current | 800 | mA |
| Collector dissipation | 60 | kW |
| Load VSWR (see note 8) | 1.5:1 | |
| Temperature of any part of tube envelope | 130 | °C |
| Grid to cathode bias voltage | -200 | V dc |
| Grid current | ±150 | mA |
| Ion pump current (beam on) | 20 | μA |
| Body current | 50 | mA |

Digital

| | | |
|---|-----|----|
| Beam current (mean) | 2.5 | A |
| Peak drive power (see note 9) | 1.1 | kW |
| Average drive power | 300 | W |
| Average output power | 30 | kW |

Analogue

| | | |
|---|-----|----|
| Beam current (sync.) | 4.5 | A |
| Drive power (peak sync.) (see note 9) | 650 | W |
| Peak sync. vision only output power | 77 | kW |
| Instantaneous peak RF output power: | | |
| when operating at 35 kV | 95 | kW |
| when operating at 32 kV | 75 | kW |
| when operating at 30 kV | 63 | kW |

Other Ratings

| | | |
|---|--------------------------|---------|
| Minimum quiescent current | 100 | mA |
| Altitude (see note 4) | up to 2286 up to 7500 | m ft |
| X-ray radiation (see Health and Safety Hazards, page 10) | 2 | μSv/hr |

TYPICAL OPERATION – Digital

(See note 10)

| | | | | |
|---|-----|-----|-----|-------------|
| Peak output power | 77 | 94 | 110 | kW |
| Average output power | 20 | 24 | 28 | kW |
| Peak input power | 615 | 750 | 875 | W |
| Average input power | 155 | 190 | 220 | W |
| Beam voltage | 32 | 34 | 36 | kV |
| Beam current (average) | 1.4 | 1.6 | 1.8 | A |
| Quiescent beam current | 500 | 600 | 700 | mA |
| Body current (DC) | 5 | 5 | 5 | mA |
| Body current (RF) | 10 | 13 | 18 | mA |
| Grid bias voltage with respect to cathode | | | | see note 11 |
| Efficiency | 43 | 45 | 41 | % |

TYPICAL OPERATION – Analogue

(System G)

Common Amplifier Service (Mono Sound)

(See notes 2 and 12)

| | | | | |
|---|-----|------------|------|-------------|
| Visual output power (peak sync.) | 44 | 55 | 63 | kW |
| Aural output power | 4.4 | 5.5 | 3.15 | kW |
| Instantaneous peak sync. output power | 76 | 95 | 95 | kW |
| Beam voltage | 32 | 35 | 35 | kV |
| Quiescent beam current | | 0.4 to 0.7 | | A |
| Grid bias voltage with respect to cathode voltage | | | | see note 11 |
| Beam current (peak sync.) | 2.4 | 2.85 | 3.3 | A |
| Drive power (vision peak sync.) | 250 | 200 | 320 | W |
| Drive power (aural) | 25 | 20 | 12 | W |
| Body current (RF) | 13 | 18 | 22 | mA |
| Figure of Merit (see note 13) | 100 | 100 | 110 | % |

Visual Service

| | | | | |
|---|------|------|------|-------------|
| Output power (peak sync.) | 55 | 64 | 75 | kW |
| Beam voltage | 32 | 32 | 35 | kV |
| Beam current (peak sync.) | 3.15 | 3.25 | 3.55 | A |
| Beam current (black level) | 1.8 | 2.1 | 2.4 | A |
| Beam current (grey level) | 1.4 | 1.6 | 1.8 | A |
| Grid bias voltage with respect to cathode voltage | | | | see note 11 |
| Drive power (peak sync.) | 280 | 330 | 330 | W |
| Conversion efficiency (peak sync.) | 55 | 57 | 60 | % |
| Body current (RF) | 15 | 20 | 25 | mA |
| Figure of Merit (see note 14) | 120 | 120 | 120 | % |

Aural Service (See note 15)

| | | | | |
|--------------------------------------|-----|------|-----|-------------|
| Output power | 14 | 27 | 31 | kW |
| Beam voltage (see note 16) | 26 | 32 | 35 | kV |
| Quiescent current | 300 | 300 | 350 | mA |
| Beam current (drive on) | 1.1 | 1.55 | 1.6 | A |
| Grid bias voltage | | | | see note 11 |
| Drive power | | | | see note 1 |
| Body current | 25 | 25 | 25 | mA |
| Figure of Merit | 49 | 55 | 55 | % |

NOTES

1. The gain of the IOT is a frequency dependent function and follows the trend shown in Fig. 1.

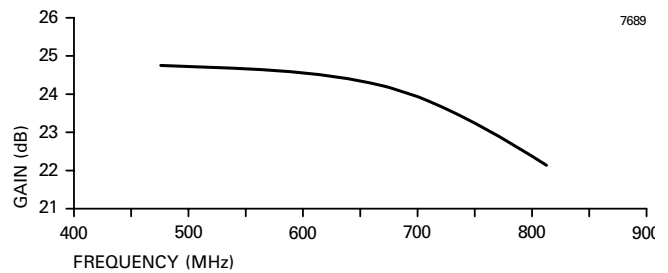

Fig. 1. IOTD2100 typical gain characteristic

2. Common amplifier service is the use of a single IOT to transmit both the visual and aural services. The data assumes that a single sound carrier is being transmitted. The peak instantaneous RF output for mono sound is calculated by the formula:

$$P = V (1 + \sqrt{A})^2$$

where P is the peak RF output power, V is the peak sync. visual output power and A is the ratio of aural power to peak sync. visual power.

If two aural carriers are to be transmitted, the peak instantaneous RF output power is calculated by the formula:

$$P = V (1 + \sqrt{A} + \sqrt{S})^2$$

where S is the ratio of second aural carrier power to peak sync. visual power.

3. **Heater Voltage**

The actual heater voltage to be used on a particular IOTD2100 is advised with the tube. The heater voltage should be stabilised to within ± 0.15 V of the recommended value.

Passive Standby and Quick-Start Modes

Passive standby is defined as any time period exceeding 30 minutes when the IOT is operated without beam voltage present but with the heater powered. The ion pump and all cooling must be operated normally in this situation.

Where an IOT is being used in a passive standby transmitter, several options exist for the mode of IOT passive operation:

Background Heat Passive Standby Mode

The IOTD2100 must be operated with a Background Heat filament voltage 1.25 V less than the nominal heater voltage advised on the test record for a particular IOT, and in no circumstances should the Background Heat heater voltage be less than 6.0 V.

The Background Heat heater voltage should be measured at the terminals of the IOT input cavity junction box in the normal way.

If a passive standby transmitter is needed for transmission, the heater voltage should be raised to its rated value and other auxiliary supplies activated. Provided that the grid bias voltage is present, the beam voltage and RF drive may be applied to the tube simultaneously. Precautions must be taken to ensure that the IOT is not overdriven, for example by disabling the transmitter a.g.c. system for a period of about five minutes.

Background heat must have been applied for at least 30 minutes from cold start before the transmitter can be considered available for transmission. Alternatively, both "Active" and "Standby" transmitters may be started from cold using the normal, 5-minute, start procedure. The "Standby" transmitter is then switched to Background Heat and is available to take over transmission if required.

Where Background Heat Passive Reserve is the normal operating mode with a pair of identical transmitters, the transmitter designated as "Standby" must become the "Active" transmitter after a period not exceeding 14 days and must remain designated "Active" for a period of not less than 7 days.

If a hydrogen thyratron crowbar is used in the "Standby" transmitter it should be permanently powered to full operational status.

Filament hours accumulated under Background Heat conditions do not count as warranty hours, provided that the above conditions are met and that there are proper means to distinguish Background Heat hours from normal heater hours.

"Soft Start"

It is recommended that a "soft start" procedure should be used in the application of the RF drive when the IOT is powered either from cold or from background heat.

The RF drive may be applied simultaneously with the beam voltage and with a typical rise time of 4 seconds.

Near-instantaneous Start – Quiescent Passive Standby

A nearly instantaneous start from standby can be achieved by operating the "Standby" transmitter in a quiescent passive standby mode where the RF drive only is removed from the IOT and the tube operates with the normal beam voltage applied. The tube draws a quiescent current (which may be lower than the normal value). This slightly reduces overall system efficiency, but ensures that the standby tube is maintained in good condition and is available for near-instant start, subject to normal soft start conditions.

The minimum quiescent current that should be used in this mode is 100 mA. This will ensure the tube maintains a good vacuum and life in standby mode.

Alternatively, the quiescent current may be maintained at the normal operational level, with no adverse effects to the IOT, but with slightly reduced overall system efficiency resulting from greater standby power dissipation.

Mains Interruptions

If mains power is absent for less than or equal to 20 seconds, then the transmitter may be re-powered immediately provided that the transmitter logic is active and the power supplies are therefore re-applied in the correct order.

If mains power is absent for between 20 seconds and 5 minutes, then heater voltage should be re-applied for an equal length of time, before attempting to re-power the IOT, which should then be powered in the normal way.

If mains power is absent for more than 5 minutes, then normal cold start-up procedures should be followed.

4. The air flow value applies to transmitters at sea level where the air density is 1.22 kg/m^3 (0.076 lb/ft^3). At high altitudes, where the air density is reduced, the volume flow must be increased in the ratio of air density at sea level to air density at altitude in order to maintain the mass flow. See e2v technologies technical note TVB-TN01. For operation above 2286 m, contact e2v technologies.
5. Measured at the input monitor pipe to the circuit assembly.
6. The transmitter must be able to protect both the IOT and itself from damage in the event of an internal arc within the IOT. In such an event, the beam power must be removed from the IOT to limit the energy dissipated within it to less than 20 J. This can be achieved, for example, by the use of a crowbar circuit or a solid-state, high frequency beam voltage power supply. e2v technologies is able to supply a suitable hydrogen thyratron equipped crowbar designed expressly for use with IOTs. Details will be provided upon request. Users of IOTs should consult their transmitter manufacturer for details of the system employed in particular equipments.
7. The high voltage power supply must be designed and connected to the IOT at start-up in such a way that high voltage overshoots are minimised and do not exceed the stated maximum.
8. Typical operating performance will be obtained for a load VSWR of less than 1.1:1. The tube will not sustain damage for a load VSWR of less than 1.5:1.
9. Protection circuits in the transmitter must ensure that it is not possible for RF drive power to be applied to the IOT in the absence of beam voltage. Failure to do so may result in serious damage to the IOT.
10. The tube can amplify either European (COFDM) or US (8-VSB) system digital signals. The typical data shown is for 8-VSB operation with a peak-to-average digital power ratio of 6.3 dB.
Operation under COFDM conditions necessitates a much higher peak-to-average ratio, and this results in a reduction of the average power whilst maintaining the peak power at the same value as for 8-VSB.
11. Grid bias should be provided by a stable regulated power supply, adjustable over the range 50 to 250 V, negative with respect to cathode voltage. Adjust to provide the required quiescent current. The supply should be able to sink or source grid current, and be smoothed to better than 0.5%.
12. Intermodulation products produced by the IOT under common amplifier conditions can be reduced further by suitable pre-correction circuitry in the transmitter.
Typically, the IOT will not introduce intermodulation products with an amplitude in excess of -45 dB with respect to peak sync. vision carrier when driven by a 40 IRE (250 mV) modulated ramp and single aural carrier at -10 dB with respect to peak sync. vision carrier.

13. The Figure of Merit (FOM) is calculated as:

$$\text{FOM} = \frac{P_V + P_A}{\text{beam power}} \times 100\%$$

where P_V is the peak sync. vision power, P_A is the aural power and the beam power is the beam power used when the visual signal consists of a mid-grey picture and syncs. Mid-grey is defined as the video voltage half way between black and white for the particular standard being used.

The FOM is a function of the bandwidth required from the IOT output circuit. The following data are typical of FOMs for different TV standards, in common amplifier mode.

| TV Standard | Bandwidth (MHz) | FOM (%) |
|-------------|-----------------|---------|
| M | 6 | 120 |
| G | 7 | 115 |
| I | 8 | 100 |

14. The Figure of Merit (FOM) is calculated as:

$$\text{FOM} = \frac{P_V}{\text{beam power}} \times 100\%$$

where P_V is the peak sync. vision power and the beam power is the beam power used when the visual signal consists of a mid-grey picture and syncs. Mid-grey is defined as the video voltage half way between black and white for the particular standard being used.

The FOM is a function of the bandwidth required from the IOT output circuit. The following data are typical of FOMs for different TV standards, in vision-only mode.

| TV Standard | Bandwidth (MHz) | FOM (%) |
|-------------|-----------------|---------|
| M | 6 | 125 |
| G | 7 | 120 |
| I | 8 | 115 |

15. Typical values mentioned apply for single sound operation. For dual sound operation beam current and drive power may require higher values, depending on the actual specification.
16. Operating from the same beam supply as the vision tube. Improved aural service efficiency can be obtained by operating the aural IOT at a beam voltage of about half the vision beam voltage.

INTELLECTUAL PROPERTY RIGHTS

This product is subject to one or more of the following US patents and corresponding patents in other countries:

| | | |
|-----------|-----------|-----------|
| US4728860 | US5239272 | US5536992 |
| US5548245 | US5581153 | US5606221 |
| US5629582 | US5691667 | |

RECOMMENDED COOLANTS

Where there is no possibility of freezing, the coolant should be good quality demineralised water. Where outside temperatures are such that pure water will freeze, then the coolant should be a mixture of equal volumes of pure demineralised water and a commercial ethylene glycol containing appropriate inhibitors and pH buffers. The concentration of glycol may be reduced in accordance with the manufacturer's instructions depending on the minimum temperature at which protection is required. When using a glycol coolant, the coolant flow rate will need to be increased to compensate for the change in heat capacity of the mixture. As an example, for a 50/50 water/glycol mixture, the flow per unit time should be increased by 14% to maintain adequate cooling.

Glycol antifreeze mixtures are prone to thermal degradation with life, especially where the coolant is oxygenated. Consequently, return pipes should discharge below the level of the coolant in reservoir tanks to minimise oxygen take-up. Coolants such as Dowtherm SR1 and Ucartherm have been examined by e2v technologies, and are believed to contain suitable pH buffers and inhibitors to make them suitable for IOT cooling.

It is recommended that the coolant is discarded after being used for one winter season to prevent the possibility of corrosion damage occurring. The transmitter should then be flushed, then operated with demineralised water during the summer before being replaced by a fresh glycol mixture before the onset of the following winter.

The use of unbuffered and uninhibited ethylene glycol will lead to corrosion damage to both the cooling system and the IOT and should not be used.

STARTING THE TRANSMITTER AT VERY LOW AMBIENT TEMPERATURES

At very low coolant temperatures, around $-20\text{ }^{\circ}\text{C}$ ($-4\text{ }^{\circ}\text{F}$), the ability of glycol/water mixtures to remove heat is severely reduced. Before powering the IOT at full beam power, the coolant should be at a temperature of at least $5\text{ }^{\circ}\text{C}$ ($41\text{ }^{\circ}\text{F}$). Therefore, at lower temperatures it should be prewarmed by running the IOT on idle current only or by any other appropriate means. For example, allowing the coolant to circulate all night during periods of very low ambient temperature may maintain the coolant temperature around $5\text{ }^{\circ}\text{C}$, due to the dissipation of the energy consumed by the circulating pump, provided that the cooling fan on the heat exchanger is turned off.

OUTLINE OF IOTD2100
 (All dimensions without limits are nominal)

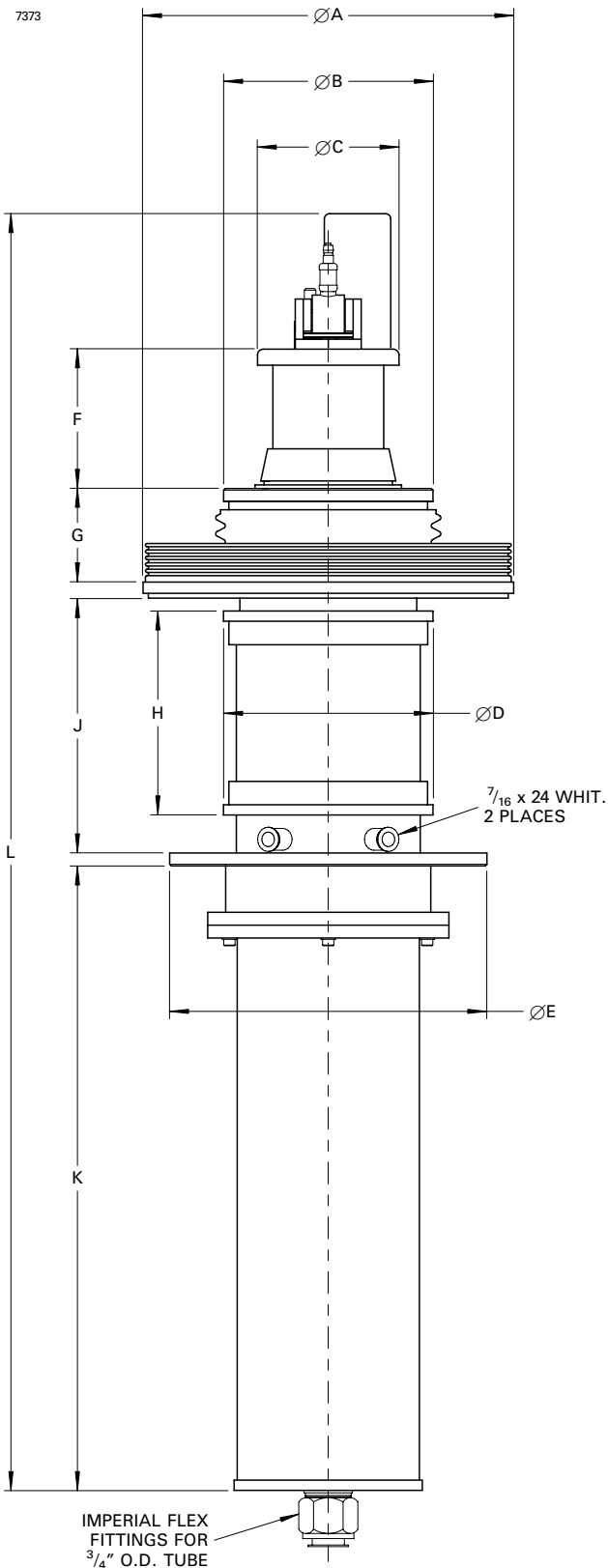

| Ref | Millimetres | Inches |
|-----|---------------|---------------|
| A | 230.4 | 9.071 |
| B | 130.05 ± 0.30 | 5.120 ± 0.012 |
| C | 93.0 | 3.661 |
| D | 130.05 ± 0.30 | 5.120 ± 0.012 |
| E | 197.15 | 7.762 |
| F | 87.5 | 3.445 |
| G | 58.25 | 2.293 |
| H | 127.0 | 5.000 |
| J | 158.7 | 6.248 |
| K | 385.5 | 15.177 |
| L | 792.5 | 31.201 |

Inch dimensions have been derived from millimetres.

Enlarged View of Gun End of Tube

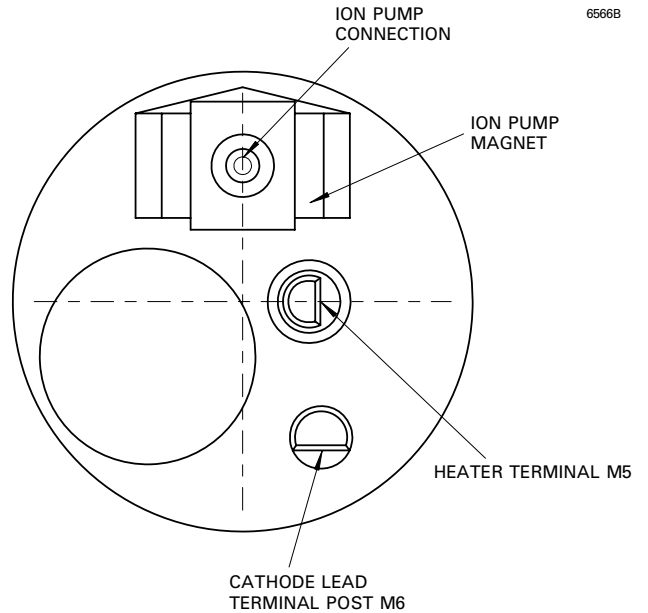

6566B

OUTLINE OF CIRCUIT ASSEMBLY IMD2000
 (All dimensions without limits are nominal)

7413A

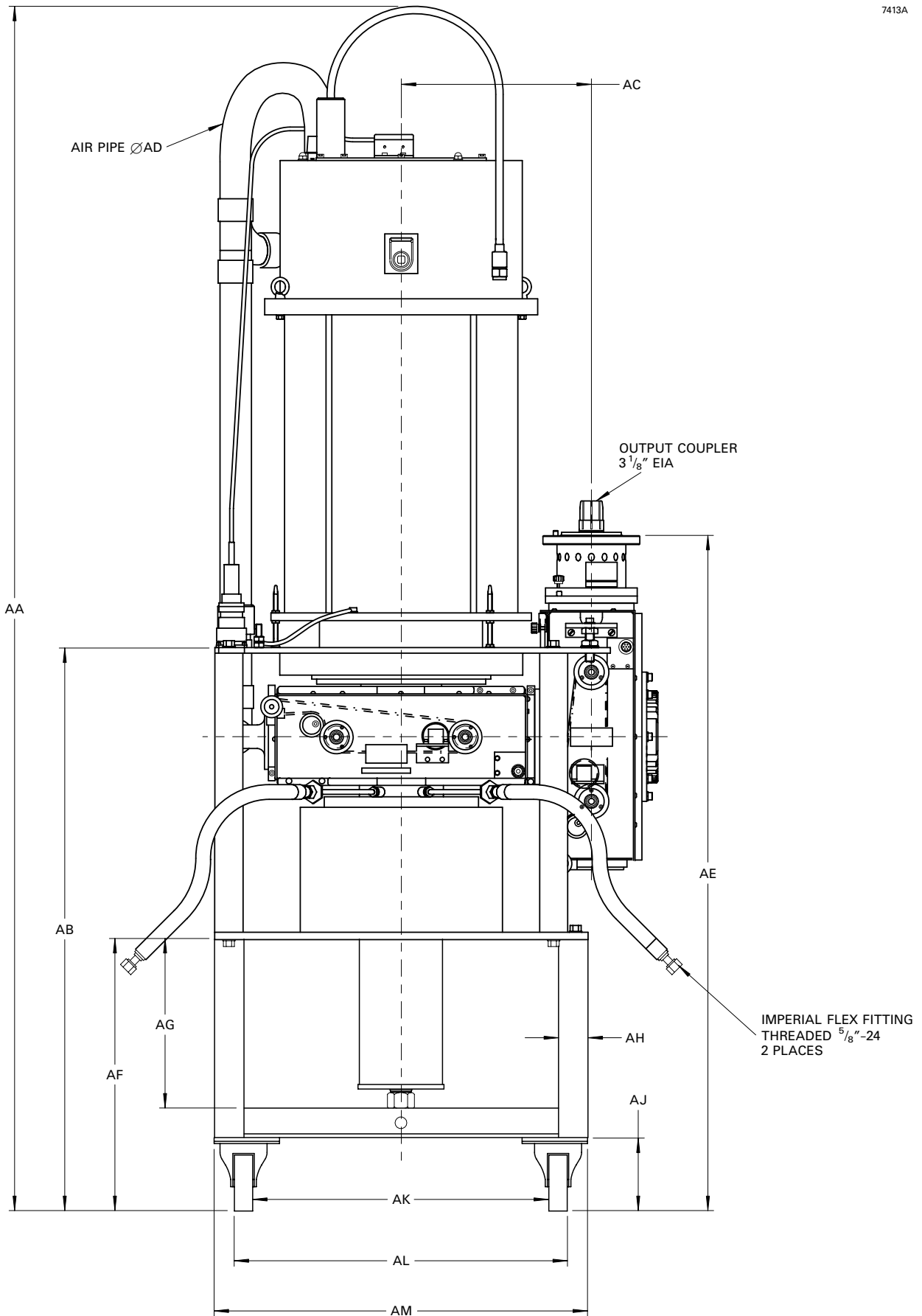

SIDE VIEW OF CIRCUIT ASSEMBLY

7414A

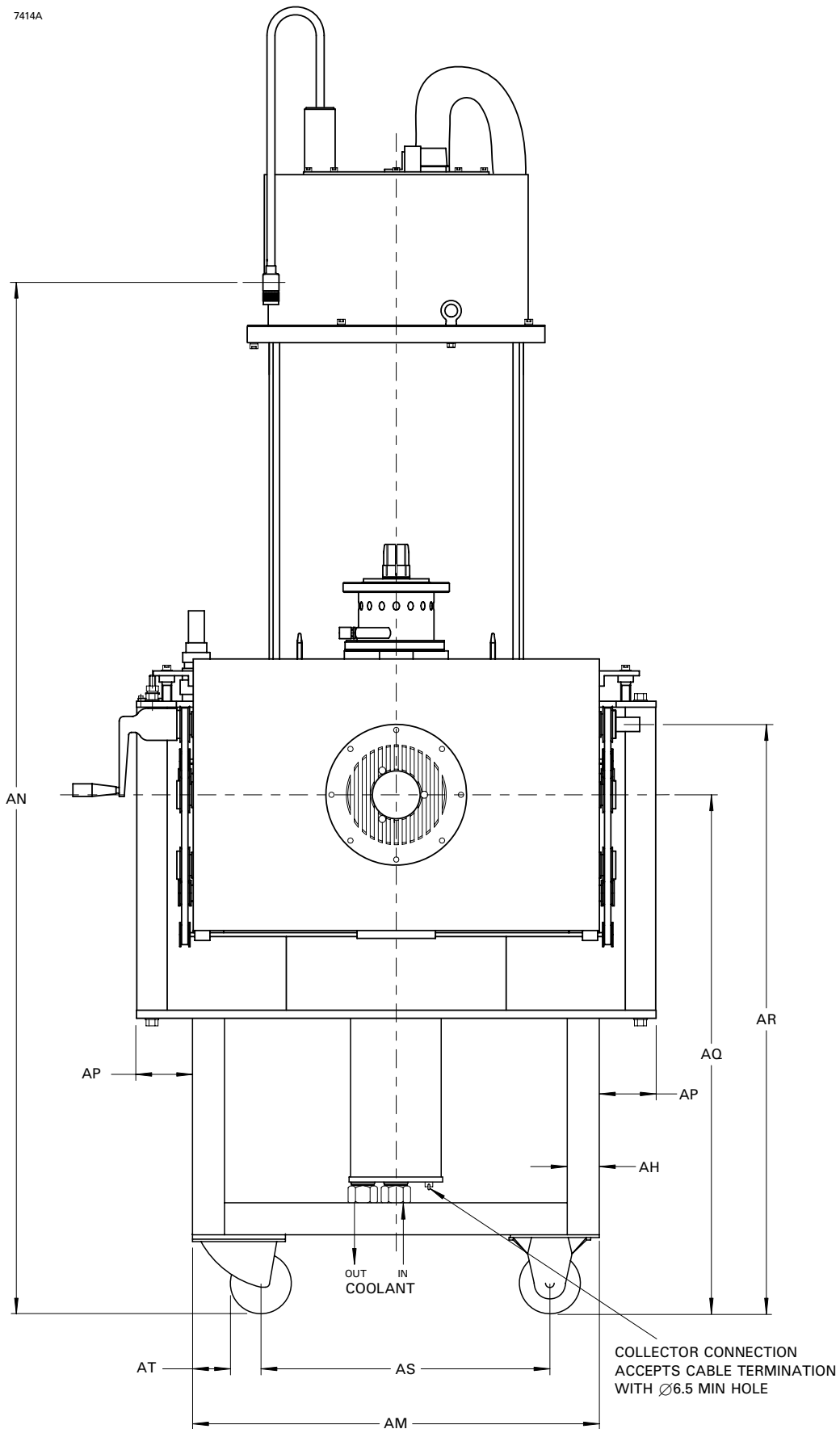

TOP VIEW OF CIRCUIT ASSEMBLY

(All dimensions nominal)

7415A

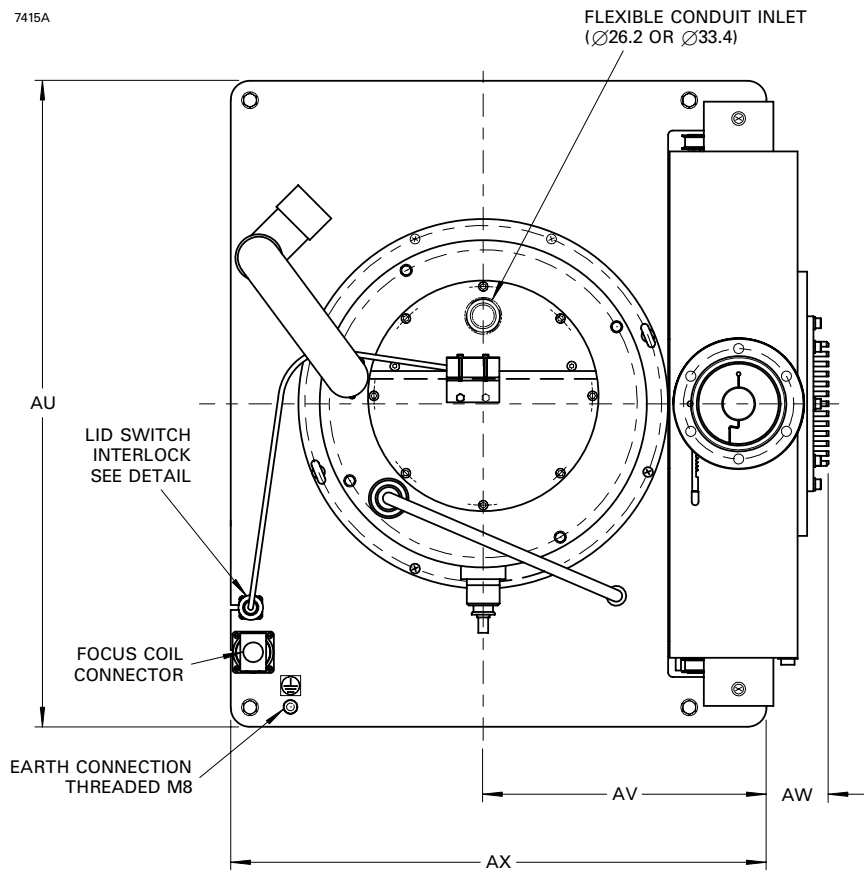

| Ref | Millimetres | Inches |
|-----|-------------|------------|
| AA | 1730.0 max | 68.110 max |
| AB | 766.0 | 30.157 |
| AC | 258.4 | 10.173 |
| AD | 42.5 | 1.673 |
| AE | 923.2 | 36.346 |
| AF | 370.0 | 14.567 |
| AG | 230.0 | 9.055 |
| AH | 40.0 | 1.575 |
| AJ | 100.0 | 3.937 |
| AK | 403.4 | 15.882 |
| AL | 453.4 | 17.850 |
| AM | 508.0 | 20.000 |
| AN | 1288.47 | 50.727 |
| AP | 71.0 | 2.795 |
| AQ | 648.8 | 25.543 |
| AR | 736.8 | 29.008 |
| AS | 400.0 | 15.748 |
| AT | 25.8 | 1.016 |
| AU | 650.0 | 25.591 |
| AV | 285.0 | 11.220 |
| AW | 62.0 | 2.441 |
| AX | 539.0 | 21.220 |

Inch dimensions have been derived from millimetres.

View on Focus Coil Connector

Connections

| Pin | Element |
|-----|---------------------|
| A | Lid switch |
| B | Focus coil positive |
| C | Lid switch |
| D | Focus coil negative |

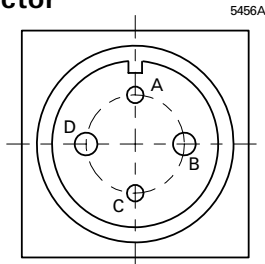

Pins A and C are connected within the circuit assembly for use as an interlock circuit; this connection may be removed by the customer if required for other purposes, but the loss of interlock should be borne in mind.

Lid Switch Interlock

Connections

| Pin | Connection |
|-----|---------------|
| A | Lid switch |
| B | Lid switch |
| C | Not connected |

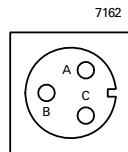

The lid switch is connected between pins A and C of the focus coil connector socket. The lid switch contacts are rated at 480 V ac or 28 V dc at 15 A.

Arc Detector Connections to socket type Amphenol T3476-001

MA257E uses a panel plug and free socket.

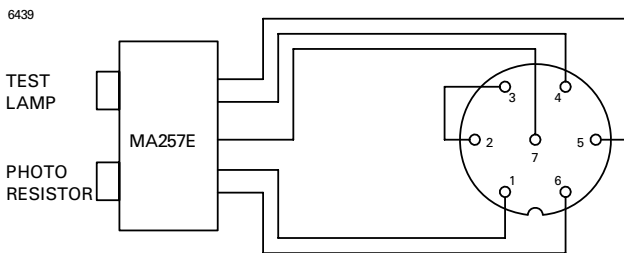

HEALTH AND SAFETY HAZARDS

High power IOTs can be hazardous to life and health if they are not installed, operated and maintained correctly, or if an IOT is damaged. e2v technologies does not accept responsibility for damage or injury resulting from the use of e2v technologies IOTs. Equipment manufacturers and IOT users should ensure that precautions are taken. Appropriate warning labels and notices must be provided on equipment incorporating IOTs and in operating manuals.



High Voltage

Equipment must be designed so that operators cannot come into contact with high voltage circuits. IOT enclosures should have fail-safe interlocked switches to disconnect the primary power supply and discharge all high voltage capacitors before allowing access.

Whilst e2v technologies has taken care to ensure the accuracy of the information contained herein it accepts no responsibility for the consequences of any use thereof and also reserves the right to change the specification of goods without notice. e2v technologies accepts no liability beyond that set out in its standard conditions of sale in respect of infringement of third party patents arising from the use of tubes or other devices in accordance with information contained herein.



RF Radiation

Personnel must not be exposed to excessive RF radiation. All RF connectors and cavities must be correctly fitted before operation, so that there is no leakage of RF energy. IOTs must not be operated without a suitable RF load at the output and intermediate cavities. It is particularly dangerous to look into open waveguide or coaxial feeders, or transmitter antennae.



X-Ray Radiation

All high voltage devices produce X-rays during operation and may require shielding. When e2v technologies IOTs are operated normally with the RF cavities fitted, some protection is provided but further shielding may be required. A suitably designed equipment cabinet will provide sufficient additional shielding. However, it is strongly recommended that all complete equipments containing operating IOT systems should be measured to establish that external X-ray levels comply with local regulations.



Mechanical

The circuit assembly has been designed to occupy the minimum of floor space in the transmitter. The wheel base is, therefore, short in relation to the height of the assembly, which has a high centre of gravity. Care is required when wheeling the magnet frame, and in particular, the IOT assembled in the magnet frame, over uneven surfaces or gradients which could cause the assembly to overbalance.



Hot Surfaces

Surfaces of tubes (for example the tube envelope in the gun region and the collector manifold in an air-cooled tube) can reach high temperatures (in some cases in excess of 100 °C) during operation and may remain at a high temperature for a considerable time after switch-off. Burns may be sustained if direct contact is made with hot surfaces.



Toxic

IOTs and ESCIOTs all contain industry standard cathode assemblies as part of the electron gun. The cathode assembly contains small quantities of various refractory metals. In normal operation, the presence of these materials requires no special precautions as they are sealed in vacuum. However, in the event of a catastrophic tube failure, resulting in loss of vacuum and exposure of a hot cathode to the atmosphere, these metals can form volatile oxides that are potentially hazardous to health. In such circumstances, operators should avoid inhaling vapours in close proximity to the tube and allow it to cool to room temperature before removing it from equipment. Broken tubes should be repacked carefully in their original packaging and returned to e2v technologies for safe disposal.